

## 20. スprayヘッド(ストレート) (SH)

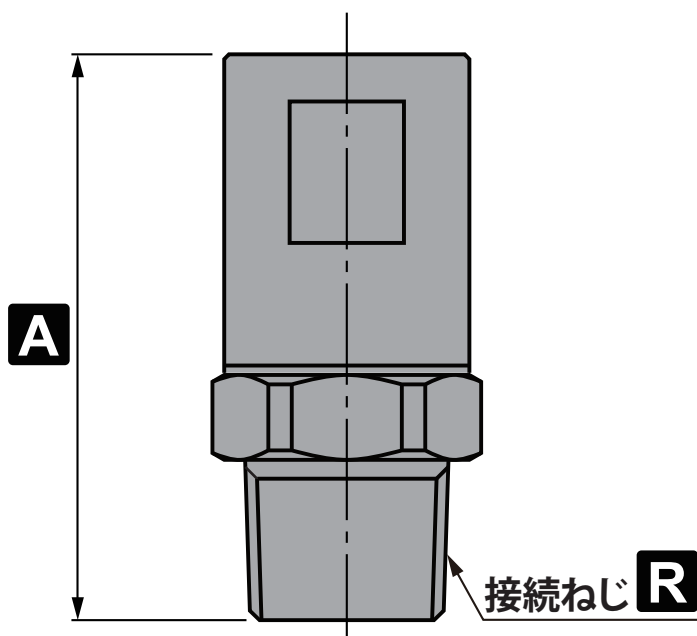

型式	圧力 [MPa]	吐出量 [L/min]	散布角度 [°]	各部寸法[mm]	
				A	R
SH-2-22-120°-4S	0.2	22	120	60	R1/2
SH-3.5-30-90°-4S	0.35	30	90	52.5	
SH-3.5-30-120°-4S	0.35	30	120	60	R3/4
SH-3.5-45-90°-6S	0.35	45	90	59	
SH-3.5-45-120°-6S	0.35	45	120	66	R1
SH-3.5-70-90°-8S	0.35	70	90	67	
SH-3.5-90-90°-8S	0.35	90	90	75	
SH-3.5-70-120°-8S	0.35	70	120	73	
SH-3.5-90-120°-8S	0.35	90	120	81	